

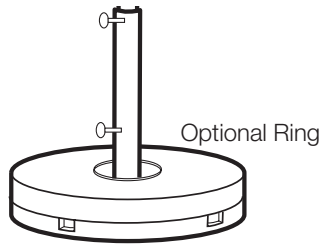

View Product



35 lb. Ring - Optional

Ring diameter:	20"
Total height:	2"
Hole diameter:	6.4"
Unit weight:	35 lbs

35 lb. Umbrella Base

Base diameter:	20"
Total height:	12"
Base height:	4"
Stem height:	8"
Stem hole diameter:	1.5"
Unit weight:	36.95 lbs

# 35 lb. Umbrella Base

with Optional 35 lb. ring for additional stability

## Product Specifications

Product Description	Reference Number	Color	UPC Code 014306	Pack Weight Each (lbs.)	Master Pack	Master Pack Volume (cu. ft)
35 lb. Umbrella Base	US600604	White	912783	37.00	1	1.66
	US600666	Sand	912790	37.00	1	1.66
	US600617	Black	912806	37.00	1	1.66
	US600637	Bronze	912820	37.00	1	1.66
Optional 35 lb. ring for additional stability	US106604	White	919416	36.00	1	0.66
	US106666	Sand	919423	36.00	1	0.66
	US106617	Black	919430	36.00	1	0.66
	US106637	Bronze	919447	36.00	1	0.66

## Features & Benefits Warranty: 1 Yr.

- Specifically designed to hold a table umbrella.
- 35 lb. cement-filled resin.
- Optional 35 lb. ring for increased stability.
- Molded anchor bolt holes to secure base to deck for extra stability.
- Long, reinforced stem with two thumb screws specifically designed for any umbrella with a 1-1/2" pole.
- Will not rust or mark your deck.
- U.V. resistant and easy to clean with soap and water.

Our umbrella bases are available in a variety of sizes and materials to fit your needs. Be sure to measure where you will be using your base to ensure fit. Your Grosfillex representative can assist you in determining the best base for your needs.

**⚠️ WARNING: Cancer - [www.P65Warnings.ca.gov](http://www.P65Warnings.ca.gov).**

**⚠️ AVERTISSEMENT: Cancer - [www.P65Warnings.ca.gov](http://www.P65Warnings.ca.gov).**

**⚠️ ADVERTENCIA: Cáncer - [www.P65Warnings.ca.gov](http://www.P65Warnings.ca.gov).**



# 35 lb. Umbrella Base

Spare Parts

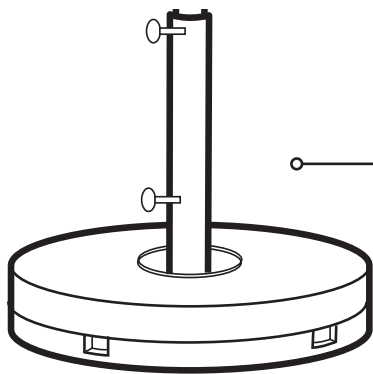

Stem USSP0255, USSP026, USSP0257, USSP0258



Components



Assembled Stem

Reference	Description
USSP0255	STEM 35LB 12" UMB BASE WHITE
USSP0256	STEM 35LB 12" UMB BASE SAND
USSP0257	STEM 35LB 12" UMB BASE BRONZE
USSP0258	STEM 35LB 12" UMB BASE BLACK

