

# Jamaica Beach Stacking Chaise

Seat Height: 14"  
 Sleigh Length: 73.5"  
 Width: 27.5"  
 Weight: 25.6 lbs

16/pack

## Product Specifications

Product Description	Reference Number	Color	UPC Code 014306	Weight Each (lbs.)	Master Pack	Master Pack Volume (cu. ft)
Jamaica Beach Stacking Chaise White Frame	UT878152	Fern Green	946368	29.25	16	127.71
	UT876006	Blue	945958	29.25	16	127.71
	UT878241	Turquoise	946382	29.25	16	127.71
	UT878019	Orange	946351	29.25	16	127.71
	UT878194	Sky Blue	946375	29.25	16	127.71
	UT878552	Beige	946399	29.25	16	127.71
	UT116004	Straw	946313	29.25	16	127.71
Sandstone Frame	UT167181	French Taupe	946344	29.25	16	127.71
French Taupe Frame	UT116181	Straw	946320	29.25	16	127.71

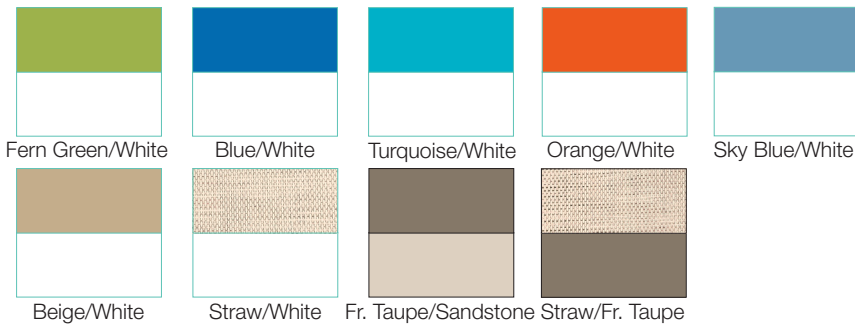

- Passes ASTM F 1988-99 Class B performance standard for commercial use
- Versatile sling chaise with many end-uses on both hard and sandy surfaces and at value pricing.
- 4-position adjustable sling chaise lounge for extra comfort
- Highly durable, mildew, stain and fade resistant PVC coated polyester fabric specifically woven to perform in commercial outdoor environments.
- Microban® anti-microbial treatment.
- Breathable power washable fabric for ease of maintenance.
- Rated to 300 lbs. for structural strength. Tested to 400 lbs. in compliance with ASTM F 1988-99 test standard.
- Recessed wheels for ease of transportation. Stacks for easy storage.
- Hard wearing footpads for extra wear resistance.
- 100% Recyclable

Spare Parts

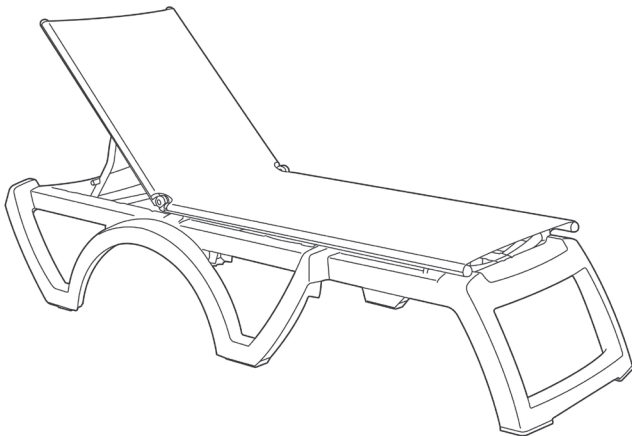

Footpads USSP0293 & USSP0294

Front Footpads (1 right, 1 left)



Middle Footpads (2 footpads)



Rear Footpads (1 right, 1 left)



Reference	Description
USSP0293	JAVA/CAPLYSPO CHAISE FOOTPAD SET WHITE
USSP0294	JAVA/CAPLYSPO CHAISE FOOTPAD SET BLACK
USSP0328	REPL SLING HDW KIT JAVA/JB CHAISE



# Jamaica Beach Stacking Chaise

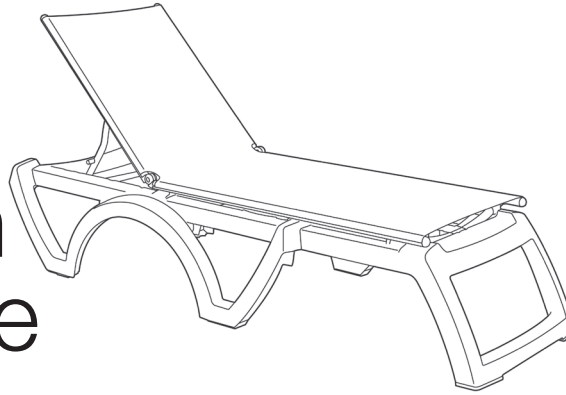

Seat Height: 14"  
 Sleigh Length: 73.5"  
 Width: 27.5"  
 Weight: 25.6 lbs

2/pack

## Product Specifications

Product Description	Reference Number	Color	UPC Code 014306	Weight Each (lbs.)	Master Pack	Master Pack Volume (cu. ft)
Jamaica Beach Stacking-Chaise White Frame	UT747152	Fern Green	942742	37.50	2	40.44
	UT747006	Blue	942728	37.50	2	40.44
	UT747241	Turquoise	931388	37.50	2	40.44
	UT747019	Orange	942735	37.50	2	40.44
	UT747194	Sky Blue	942759	37.50	2	40.44
	UT747552	Beige	942773	37.50	2	40.44
	UT120004	Straw	942766	37.50	2	40.44
Sandstone Frame	UT679181	French Taupe	942711	37.50	2	40.44
French Taupe Frame	UT120181	Straw	942704	37.50	2	40.44

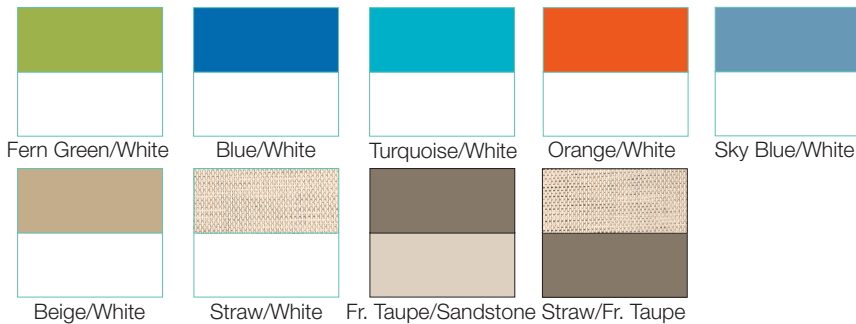

- Passes ASTM F 1988-99 Class B performance standard for commercial use
- Versatile sling chaise with many end-uses on both hard and sandy surfaces and at value pricing.
- 4-position adjustable sling chaise lounge for extra comfort
- Highly durable, mildew, stain and fade resistant PVC coated polyester fabric specifically woven to perform in commercial outdoor environments.
- Microban® anti-microbial treatment.
- Breathable power washable fabric for ease of maintenance.
- Rated to 300 lbs. for structural strength. Tested to 400 lbs. in compliance with ASTM F 1988-99 test standard.
- Recessed wheels for ease of transportation. Stacks for easy storage.
- Hard wearing footpads for extra wear resistance.
- 100% Recyclable

Spare Parts

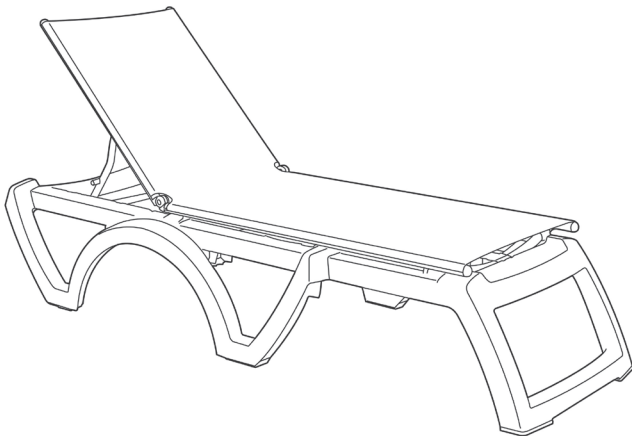

Footpads USSP0293 & USSP0294

Front Footpads (1 right, 1 left)



Middle Footpads (2 footpads)



Rear Footpads (1 right, 1 left)



Reference	Description
USSP0293	JAVA/CAPLYSPO CHAISE FOOTPAD SET WHITE
USSP0294	JAVA/CAPLYSPO CHAISE FOOTPAD SET BLACK
USSP0328	REPL SLING HDW KIT JAVA/JB CHAISE